



Standard Test Method for Flexural Strength of Hydraulic-Cement Mortars¹

This standard is issued under the fixed designation C 348; the number immediately following the designation indicates the year of original adoption or, in the case of revision, the year of last revision. A number in parentheses indicates the year of last reapproval. A superscript epsilon (ϵ) indicates an editorial change since the last revision or reapproval.

1. Scope*

1.1 This test method covers the determination of the flexural strength of hydraulic-cement mortars.

1.2 The values stated in SI units are to be regarded as standard. No other units of measurement are included in this standard.

1.3 Values in SI units shall be obtained by measurement in SI units or by appropriate conversion, using the Rules for Conversion and rounding given in Standard [IEEE/ASTM SI 10](#), of measurements made in other units.

1.4 *This standard does not purport to address all of the safety concerns, if any, associated with its use. It is the responsibility of the user of this standard to establish appropriate safety and health practices and determine the applicability of regulatory limitations prior to use. (Warning—Fresh hydraulic cementitious mixtures are caustic and may cause chemical burns to skin and tissue upon prolonged exposure.)*²

2. Referenced Documents

2.1 *ASTM Standards:*³

[C 109/C 109M Test Method for Compressive Strength of Hydraulic Cement Mortars \(Using 2-in. or \[50-mm\] Cube Specimens\)](#)

[C 230/C 230M Specification for Flow Table for Use in Tests of Hydraulic Cement](#)

[C 305 Practice for Mechanical Mixing of Hydraulic Cement Pastes and Mortars of Plastic Consistency](#)

[C 349 Test Method for Compressive Strength of Hydraulic-Cement Mortars \(Using Portions of Prisms Broken in Flexure\)](#)

[C 670 Practice for Preparing Precision and Bias Statements for Test Methods for Construction Materials](#)

[C 778 Specification for Standard Sand](#)

[C 1005 Specification for Reference Masses and Devices for Determining Mass and Volume for Use in the Physical Testing of Hydraulic Cements](#)

[C 1437 Test Method for Flow of Hydraulic Cement Mortar IEEE/ASTM SI 10 Standard for Use of the International System of Units \(SI\): The Modern Metric System](#)

3. Summary of Test Method

3.1 The test mortar used consists of 1 part cement and 2.75 parts of sand proportion by mass. Portland or air-entraining portland cements are mixed at specified water-cement ratios. Water content of other cements is that sufficient to obtain a flow of $110 \pm 5\%$ with 25 drops of the flow table. Test prisms, 40 by 40 by 160-mm are molded by tamping in two layers. Prisms are cured one day in the molds and stripped until tested by center point loading.

4. Significance and Use

4.1 This test method provides a means for determining the flexural strength of hydraulic cement mortars. Portions of the mortar prisms tested in flexure according to this test method may be used for the determination of compressive strength in accordance with Test Method [C 349](#).

4.2 The values are determined from this test method for research or reference purposes only and are not used for determining compliance with specification requirements.

5. Apparatus

5.1 *Weights, Weighing Devices and Glass Graduates*, shall conform to the requirements of Specification [C 1005](#). The balance shall be evaluated for precision and accuracy at 2000 g.

5.2 *Mixer, Bowl and Paddle*, an electrically driven mechanical mixer of the type equipped with paddle and mixing bowl, as specified in the Apparatus Section of Practice [C 305](#).

5.3 *Flow Table and Flow Mold*, shall conform to Specification [C 230/C 230M](#).

5.4 *Specimen Molds*—Molds for the 40 by 40 by 160-mm prism specimens shall be triple-gang molds and shall be so designed that the specimens will be molded with their longitudinal axes in a horizontal position. The molds shall be made of a hard metal, not attacked by cement mortar, and with a Rockwell hardness of not less than HRB 55. The parts of the

¹ This test method is under the jurisdiction of ASTM Committee C01 on Cement and is the direct responsibility of Subcommittee C01.27 on Strength.

Current edition approved Dec. 1, 2008. Published January 2009. Originally approved in 1954. Last previous edition approved in 2002 as C 348 – 02.

² See the section on Safety, Manual of Cement Testing, *Annual Book of ASTM Standards*, Vol 04.01.

³ For referenced ASTM standards, visit the ASTM website, www.astm.org, or contact ASTM Customer Service at service@astm.org. For *Annual Book of ASTM Standards* volume information, refer to the standard's Document Summary page on the ASTM website.

*A Summary of Changes section appears at the end of this standard.

molds shall be matchmarked and, when assembled, shall be tight-fitting and positively held together. The sides of the molds shall be sufficiently rigid to prevent spreading or warping. The interior faces of the molds shall be plane surfaces with a permissible variation, in any 50-mm line on a surface, of 0.03 mm for new molds and 0.05 mm for molds in use. The distance between opposite sides shall be 40 ± 0.13 mm for new molds and 40 ± 0.3 mm for molds in use. The height of the molds shall be 40 mm with permissible variations of +0.25 and -0.15 mm for new molds, and +0.25 and -0.40 mm for molds in use. The inside length of the molds shall be 160 ± 2.5 mm. The angle between adjacent interior faces and top and bottom planes of the mold shall be $90 \pm 0.5^\circ$, measured at points slightly removed from the intersections of the faces. The base plate shall be approximately 10 mm in thickness and shall have a plane surface 200 by 180 mm with a permissible variation in any 50-mm line on the surface of 0.03 mm.

5.5 *Tamper*—The tamper (see Fig. 1) shall be made of nonabsorptive, nonabrasive material, such as a rubber compound having a Shore A durometer hardness of 80 ± 10 or seasoned oak wood rendered nonabsorptive by immersion for 15 min in paraffin at approximately 200 °C. The face of the tamper shall be 22 by 85 mm.

5.6 *Tamper Guide*—The tamper guide (see Fig. 2), shall be made of metal (such as brass of Rockwell hardness not less than HRB 55) not attacked by the cement mortar. It shall lie flat on the mold and shall not protrude over any interior edge of the form more than 0.40 mm. The height of the guide shall be 25 mm.

5.7 *Trowel*—The trowel shall have a steel blade 115 by 250 mm in length, with straight edges.

5.8 *Flexure Testing Device*—The centerpoint loading method shall be used in making flexure tests on the prism specimens. The device used shall be designed such that the forces applied to the specimen will be vertical only and applied without eccentricity. A device that accomplishes this purpose, for use in a compression testing machine, is shown in Fig. 3. Apparatus for making flexure tests of mortar specimens shall be designed to incorporate the following principles:

5.8.1 The distance between supports and points of load application shall remain constant.

5.8.2 The load shall be applied normal to the loaded surface of the specimen and in such a manner as to avoid all eccentricity of loading.

5.8.3 The direction of the reactions should be parallel to the direction of the applied load at all times during the test.

5.8.4 The load should be applied at a uniform rate and in a manner to avoid shock.

5.9 *Compression Testing Machine*—The compression testing machine used with the flexure testing device, as shown in Fig. 3, shall be of the hydraulic type and conform to the requirements prescribed in Test Method C 109/C 109M.

NOTE 1—Most hydraulic compression machines designed for breaking 50-mm cubes have a relatively small diameter lower bearing surface directly centered below the upper spherically seated head, on which close-fitting pedestals of appropriate heights are set for breaking 50-mm cubes and 50 by 100-mm or 75 by 150-mm cylinders. The base plate of the flexure testing apparatus shown in Fig. 3 is designed to rest on the low pedestal intended for tests on 75 by 150-mm.

NOTE 2—In the absence of self-centering arrangements on machines with large lower bearing surfaces, the center of this surface directly below the center of the upper spherically seated head shall be accurately located. A circle or concentric circles of appropriate diameters shall be scribed on the lower bearing surface around this point. A cylindrical pedestal of appropriate diameter and height shall be obtained. End faces of the pedestal must be plane and parallel and at 90° to the axis of the cylinder. The upper face shall have a diameter of 77.5 mm.

6. Materials

6.1 *Graded Standard Sand*:

6.1.1 The sand used for making test specimens shall be natural silica sand and conform to Specification C 778.

7. Number of Specimens

7.1 Three or more specimens shall be made for each period of test specified.

8. Preparing Specimen Molds

8.1 Prepare the specimen molds as prescribed in Test Method C 109/C 109M.

9. Procedure

9.1 *Proportioning, Consistency, and Mixing of Mortars*—The proportioning, consistency, and mixing of the standard

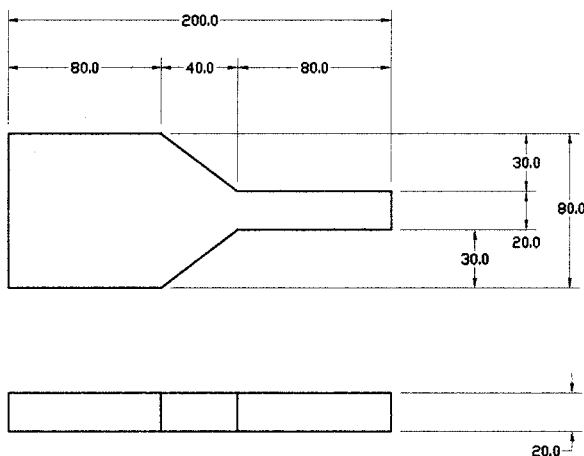
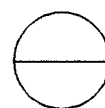

FIG. 1 Tamper

NOTE:

1. ALL DIMENSIONS IN MILLIMETERS



DETAIL / TAMPER

Scale: None

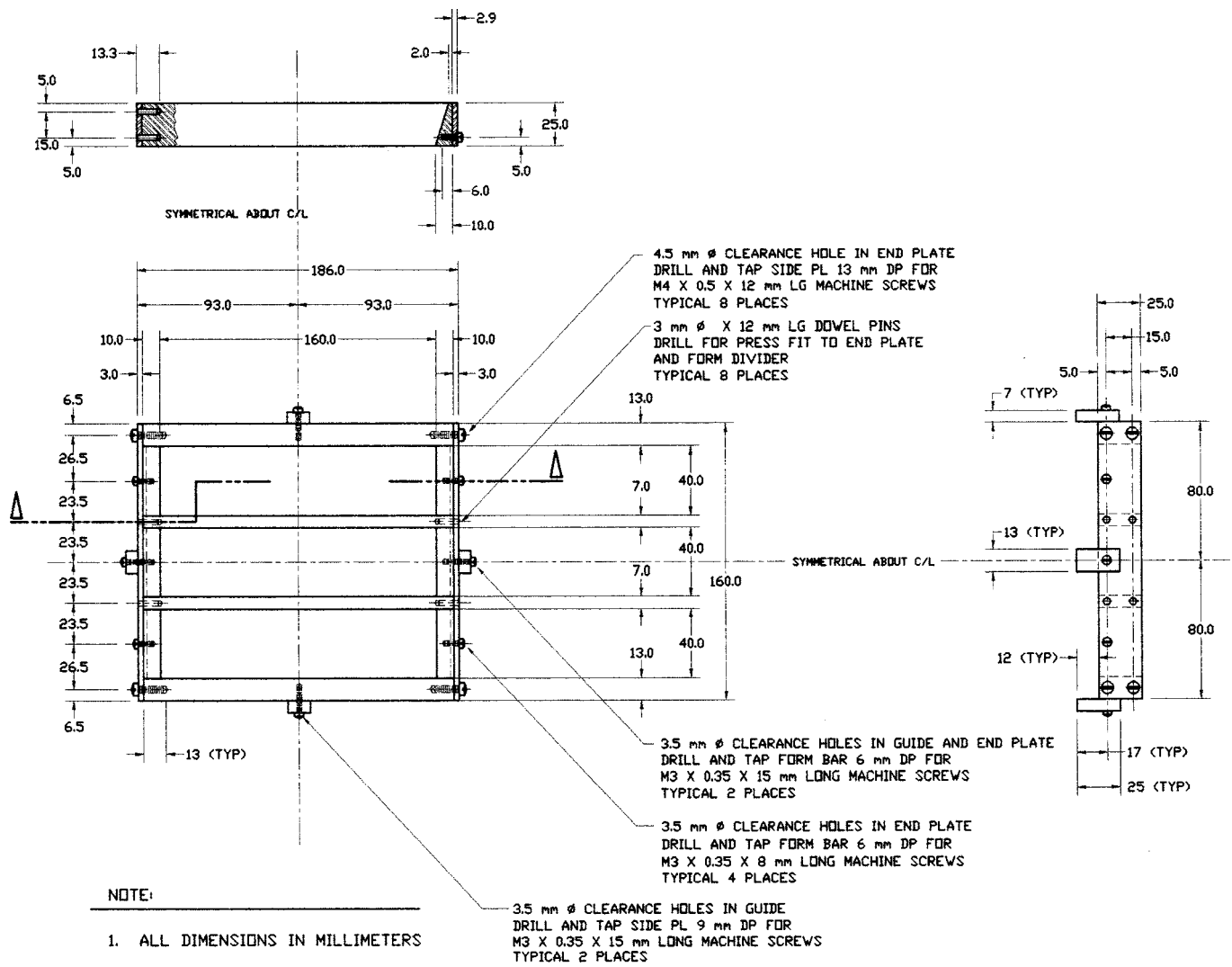

DETAIL / TAMPER GUIDE ATTACHMENT
Scale: None

FIG. 2 Tamper Guide Attachment

mortar shall be in accordance with the Procedure Section of Test Method C 109/C 109M.

9.2 *Determination of Flow*—The flow shall be determined in accordance with Test Method C 1437.

9.3 *Molding Test Specimens:*

9.3.1 Immediately following completion of the flow test, return the mortar from the flow table to the mixing bowl. Quickly scrape down into the batch the mortar that may have collected on the side of the bowl and then remix the entire batch 15 s at medium speed. Upon completion of mixing, the mixing paddle shall be shaken to remove excess mortar into the mixing bowl.

9.3.2 When a duplicate batch is to be made immediately for additional specimens, the flow test may be omitted and the mortar allowed to remain in the mixing bowl for 90 s without covering. During the last 15 s of this interval, quickly scrape

down into the batch the mortar that may have collected on the side of the bowl. Then remix for 15 s at medium speed.

9.3.3 Start molding the specimens within a total elapsed time of not more than 2 min and 30 s after completion of the original mixing of the mortar batch.

9.3.4 Evenly distribute a layer of mortar about 20 mm in thickness in each of the three molds with the tamper guide in place. Then compact the mortar in each mold by twelve strokes of the tamper, applied in three rounds of four strokes each, as shown in Fig. 4. Complete the twelve strokes in about 15 s. For each stroke hold the tamper face in horizontal position about 25 mm above the mortar level and then thrust directly downward with sufficient force to squeeze out a small amount of mortar from under the tamping surface. Fill the molds with mortar which shall be uniformly distributed and tamped in the same manner as the bottom layer. Then remove the tamper guide and

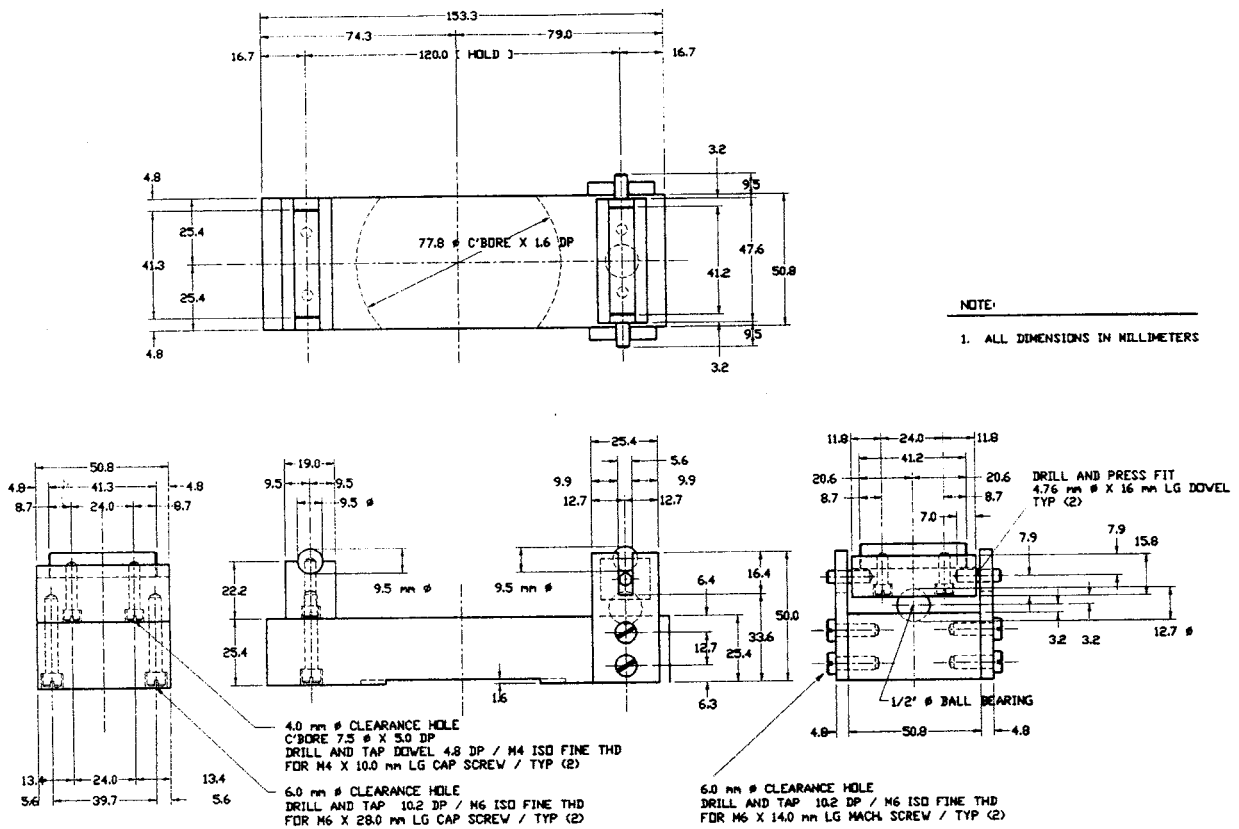

DETAIL / BASE PLATE AND SUPPORT EDGES
 Scale: None

(a) Base Plate and Support Edges.

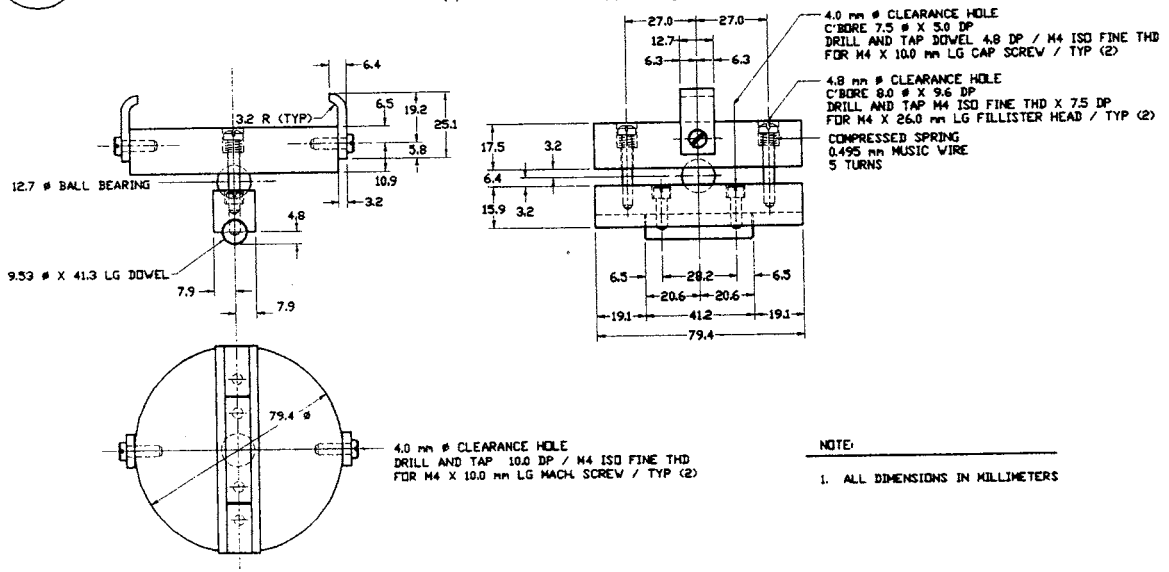

DETAIL / CENTER-POINT LOADING COMPONENT
 Scale: None

(b) Center-Point Loading Component.

FIG. 3 Special Components for Adapting Compression Testing Machine for Testing 40 by 40 by 160-mm Prisms

smooth off the specimens by drawing the flat side of the trowel (with the leading edge slightly raised) once along the length of the molds. Cut the mortar off flush with the top of the molds by

the straight edge of the trowel (held nearly perpendicular to the molds) with a sawing motion over the length of the molds. Following the cutting operation repair tears or cracks in the top

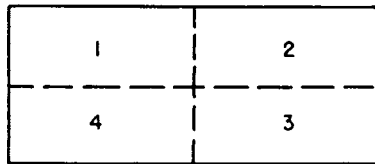

FIG. 4 Order of Tamping in Molding of Specimens (Three Rounds)

surfaces and then make the surfaces of the specimens plane by two or three light longitudinal strokes of the trowel held with the leading edge slightly raised.

9.4 *Storage of Test Specimens*—Store the test specimens in accordance with Test Method **C 109/C 109M**.

9.5 *Determination of Flexural Strength:*

9.5.1 Test the specimens immediately after their removal from the moist closet in the case of 24-h specimens and from the storage water in the case of all other specimens. All test specimens for a designated test age shall be broken within the permissible tolerance prescribed below:

Test Age	Permissible Tolerance, h
24 h	$\pm \frac{1}{2}$
3 days	± 1
7 days	± 3
28 days	± 12

When the portions of prisms are tested as modified cubes in accordance with Test Method **C 349**, test the prisms early enough so that the modified cubes are also broken within the above tolerances. If more than one specimen at a time is removed from the moist closet for the 24-h test, cover these specimens with waterproof plastic until the time of test. For older specimens, if more than one specimen at a time is removed from the storage water for testing, place these specimens in water at a temperature of 23 ± 2.0 °C and of sufficient depth to completely immerse each specimen until time of test.

NOTE 3—The flexural strength of prisms is quickly affected by drying which produces skin tension in the specimens and yields low strengths. Specimens for test at 24 h should, therefore, be removed from molds preferably at that age and tested immediately. If there is a delay in testing, specimens shall be wrapped in waterproof plastic and placed in the moist closet until immediately before testing. After breaking, rewrap in plastic until compressive tests are made.

9.5.2 Wipe each prism to a surface-dry condition, and remove any loose sand grains or incrustations from the faces that will be in contact with the bearing surfaces of the points of support and load application. Check these faces by applying a straightedge. If there is appreciable curvature, grind the face or faces to plane surfaces or discard the specimen. Cloths used for wiping 24-h specimens shall be not more than faintly damp.

9.5.3 Center the pedestal on the base plate of the machine directly below the center of the upper spherical head, and place the bearing plate and support edge assembly on the pedestal. Attach the center-loading device to the spherical head. Turn the specimen on its side with respect to its position as molded and place it on the supports of the testing device. The longitudinal center line of the specimen shall be set directly above the midpoint of both supports. Adjust the center-point loading device so that its bearing edge is at exactly right angles to the

length of the prism and parallel to its top face as placed, with the center of the bearing edge directly above the center line of the prism and at the center of the span length. Take care to ensure that contact between the specimen and loading edge is continuous when the load is applied. Apply the load at the rate of 2640 ± 110 N which shall be indicated within an accuracy of ± 1 % on a dial graduated in increments of not more than 44 N. Estimate the total maximum load to the closest 22 N.

10. Calculation

10.1 Record the total maximum load indicated by the testing machine and calculate the flexural strength (for the particular size of specimen and conditions of test herein described) in MPa as follows:

$$S_f = 0.0028 P \quad (1)$$

where:

S_f = flexural strength, MPa, and

P = total maximum load, N.

11. Faulty Specimens and Retests

11.1 Test specimens that are manifestly faulty or that result in strengths differing by more than 10 % from the average value of all test specimens made from the same sample and tested at the same period shall not be considered in determining the flexural strength. After discarding specimens or strength values, if less than two strength values are left for determining the flexural strength at any given period a retest shall be made.

12. Precision and Bias

12.1 *Precision:*

12.1.1 The following precision statements are applicable when a test result is the average of flexural strength tests of three prisms molded from a single batch of mortar and tested at the same age. They are applicable to mortars made with Type I, IA, IS, or III cement tested at 3, 7, or 28 days (1, 3, or 7 days for Type III cement).

12.1.1.1 *Multilaboratory Precision*—The multilaboratory coefficient of variation has been found to be 8.4 %. Therefore, results of properly conducted tests of single batches by two different laboratories should not differ by more than 23.8 % of their average.

NOTE 4—These numbers represent, respectively, the (1s %) and (d2s %) limits as described in Practice **C 670**.

12.1.1.2 *Single-Laboratory Precision*—The single-laboratory coefficient of variation has been found to be 5.1 %. Therefore, results of two properly conducted tests of single batches of mortar made with the same materials either on the same day or within the same week should not differ from each other by more than 14.4 % of their average (see **Note 4**).

12.2 *Bias*—No statement on bias is being made since there is no accepted reference material suitable for determining the bias of this test method.

13. Keywords

13.1 compressive strength; flexural strength; hydraulic-cement mortar; hydraulic-cement strength; mortar strength; strength

For additional information on details of cement test methods, reference may be made to the “Manual of Cement Testing,” which appears in the *Annual Book of ASTM Standards*, Vol 04.01.

SUMMARY OF CHANGES

Committee C01 has identified the location of selected changes to this test method since the last issue, C 348 – 02, that may impact the use of this test method. (Approved December 1, 2008)

- (1) Revised the standard to delete informational units.
- (2) Revised 5.1 to add reference to Specification C 1005.
- (3) Revised 9.2 to add reference to Test Method C 1437.

ASTM International takes no position respecting the validity of any patent rights asserted in connection with any item mentioned in this standard. Users of this standard are expressly advised that determination of the validity of any such patent rights, and the risk of infringement of such rights, are entirely their own responsibility.

This standard is subject to revision at any time by the responsible technical committee and must be reviewed every five years and if not revised, either reapproved or withdrawn. Your comments are invited either for revision of this standard or for additional standards and should be addressed to ASTM International Headquarters. Your comments will receive careful consideration at a meeting of the responsible technical committee, which you may attend. If you feel that your comments have not received a fair hearing you should make your views known to the ASTM Committee on Standards, at the address shown below.

This standard is copyrighted by ASTM International, 100 Barr Harbor Drive, PO Box C700, West Conshohocken, PA 19428-2959, United States. Individual reprints (single or multiple copies) of this standard may be obtained by contacting ASTM at the above address or at 610-832-9585 (phone), 610-832-9555 (fax), or service@astm.org (e-mail); or through the ASTM website (www.astm.org).