



Standard Test Methods for Liquid Limit, Plastic Limit, and Plasticity Index of Soils¹

This standard is issued under the fixed designation D 4318; the number immediately following the designation indicates the year of original adoption or, in the case of revision, the year of last revision. A number in parentheses indicates the year of last reapproval. A superscript epsilon (ϵ) indicates an editorial change since the last revision or reapproval.

1. Scope *

1.1 These test methods cover the determination of the liquid limit, plastic limit, and the plasticity index of soils as defined in Section 3 on Terminology.

1.2 Two methods for preparing test specimens are provided as follows: *Wet preparation method*, as described in 10.1. *Dry preparation method*, as described in 10.2. The method to be used shall be specified by the requesting authority. If no method is specified, use the wet preparation method.

1.2.1 The liquid and plastic limits of many soils that have been allowed to dry before testing may be considerably different from values obtained on non-dried samples. If the liquid and plastic limits of soils are used to correlate or estimate the engineering behavior of soils in their natural moist state, samples should not be permitted to dry before testing unless data on dried samples are specifically desired.

1.3 Two methods for determining the liquid limit are provided as follows: *Method A*, Multipoint test as described in Sections 11 and 12. *Method B*, One-point test as described in Sections 13 and 14. The method to be used shall be specified by the requesting authority. If no method is specified, use Method A.

1.3.1 The multipoint liquid limit method is generally more precise than the one-point method. It is recommended that the multipoint method be used in cases where test results may be subject to dispute, or where greater precision is required.

1.3.2 Because the one-point method requires the operator to judge when the test specimen is approximately at its liquid limit, it is particularly not recommended for use by inexperienced operators.

1.3.3 The correlation on which the calculations of the one-point method are based may not be valid for certain soils, such as organic soils or soils from a marine environment. It is strongly recommended that the liquid limit of these soils be determined by the multipoint method.

1.4 The plastic limit test is performed on material prepared for the liquid limit test.

1.5 The liquid limit and plastic limit of soils (along with the shrinkage limit) are often collectively referred to as the Atterberg limits. These limits distinguished the boundaries of

the several consistency states of plastic soils.

1.6 The composition and concentration of soluble salts in a soil affect the values of the liquid and plastic limits as well as the water content values of soils (see Method D 2216). Special consideration should therefore be given to soils from a marine environment or other sources where high soluble salt concentrations may be present. The degree to which the salts present in these soils are diluted or concentrated must be given careful consideration.

1.7 The methods described herein are performed only on that portion of a soil that passes the 425- μm (No. 40) sieve. Therefore, the relative contribution of this portion of the soil to the properties of the sample as a whole must be considered when using these tests to evaluate properties of a soil.

1.8 The values stated in acceptable metric units are to be regarded as the standard, except as noted below. The values given in parentheses are for information only.

1.8.1 The standard units for the resilience tester covered in Annex A1 are inch-pound, not metric. The metric values given are for information only.

1.9 *This standard does not purport to address all of the safety concerns, if any, associated with its use. It is the responsibility of the user of this standard to establish appropriate safety and health practices and determine the applicability of regulatory limitations prior to use.*

2. Referenced Documents

2.1 ASTM Standards:

C 702 Practice for Reducing Field Samples of Aggregate to Testing Size²

D 75 Practice for Sampling Aggregates³

D 420 Guide to Site Characterization for Engineering, Design, and Construction Purposes⁴

D 653 Terminology Relating to Soil, Rock, and Contained Fluids⁴

D 1241 Specification for Materials for Soil-Aggregate Sub-base, Base, and Surface Courses⁴

D 2216 Test Method for Laboratory Determination of Water (Moisture) Content of Soil and Rock by Mass⁴

D 2487 Practice for Classification of Soils for Engineering Purposes (Unified Soil Classification System)⁴

¹ This standard is under the jurisdiction of ASTM Committee D18 on Soil and Rock and is the direct responsibility of Subcommittee D18.03 on Texture, Plasticity and Density Characteristics of Soils.

Current edition approved June 10, 2000. Published September 2000. Originally published as D 4318 – 83. Last previous edition D 4318 – 98.

² *Annual Book of ASTM Standards*, Vol 04.02.

³ *Annual Book of ASTM Standards*, Vol 04.03.

⁴ *Annual Book of ASTM Standards*, Vol 04.08.

*A Summary of Changes section appears at the end of this standard.

D 3282 Practice for Classification of Soils and Soil-Aggregate Mixtures for Highway Construction Purposes⁴

D 3740 Practice for Minimum Requirements for Agencies Engaged in the Testing and/or Inspection of Soil and Rock as Used in Engineering Design and Construction⁴

D 4753 Specification for Evaluating, Selecting, and Specifying Balances and Scales for Use in Soil, Rock, and Related Construction Materials Testing⁴

D 6026 Practice for Using Significant Digits in Geotechnical Data⁵

E 11 Specification for Wire-Cloth Sieves for Testing Purposes⁶

E 177 Practice for Use of the Terms Precision and Bias in ASTM Test Methods⁶

E 691 Practice for Conducting an Interlaboratory Study to Determine the Precision of a Test Method⁶

3. Terminology

3.1 Definitions:

3.1.1 The definitions of terms in this standard are in accordance with Terminology D 653.

3.2 Description of Terms Specific to This Standard:

3.2.1 *Atterberg Limits*—Originally, six “limits of consistency” of fine-grained soils were defined by Albert Atterberg: the upper limit of viscous flow, the liquid limit, the sticky limit, the cohesion limit, the plastic limit, and the shrinkage limit. In current engineering usage, the term usually refers only to the liquid limit, plastic limit, and in some references, the shrinkage limit.

3.2.2 *consistency*—the relative ease with which a soil can be deformed.

3.2.3 *liquid limit (LL, w_L)*—the water content, in percent, of a soil at the arbitrarily defined boundary between the semi-liquid and plastic states.

3.2.3.1 *Discussion*—The undrained shear strength of soil at the liquid limit is considered to be approximately 2 kPa (0.28 psi).

3.2.4 *plastic limit (PL, w_p)*—the water content, in percent, of a soil at the boundary between the plastic and semi-solid states.

3.2.5 *plastic soil*—a soil which has a range of water content over which it exhibits plasticity and which will retain its shape on drying.

3.2.6 *plasticity index (PI)*—the range of water content over which a soil behaves plastically. Numerically, it is the difference between the liquid limit and the plastic limit.

3.2.7 *liquidity index*—the ratio, expressed as a percentage of (1) the water content of a soil minus its plastic limit, to (2) its plasticity index.

3.2.8 *activity number (A)*—the ratio of (1) the plasticity index of a soil to (2) the percent by mass of particles having an equivalent diameter smaller than 2 μm .

4. Summary of Test Method

4.1 The specimen is processed to remove any material retained on a 425- μm (No. 40) sieve. The liquid limit is

determined by performing trials in which a portion of the specimen is spread in a brass cup, divided in two by a grooving tool, and then allowed to flow together from the shocks caused by repeatedly dropping the cup in a standard mechanical device. The multipoint liquid limit, Method A, requires three or more trials over a range of water contents to be performed and the data from the trials plotted or calculated to make a relationship from which the liquid limit is determined. The one-point liquid limit, Method B, uses the data from two trials at one water content multiplied by a correction factor to determine the liquid limit.

4.2 The plastic limit is determined by alternately pressing together and rolling into a 3.2-mm ($1/8$ -in.) diameter thread a small portion of plastic soil until its water content is reduced to a point at which the thread crumbles and can no longer be pressed together and re-rolled. The water content of the soil at this point is reported as the plastic limit.

4.3 The plasticity index is calculated as the difference between the liquid limit and the plastic limit.

5. Significance and Use

5.1 These test methods are used as an integral part of several engineering classification systems to characterize the fine-grained fractions of soils (see Practices D 2487 and D 3282) and to specify the fine-grained fraction of construction materials (see Specification D 1241). The liquid limit, plastic limit, and plasticity index of soils are also used extensively, either individually or together, with other soil properties to correlate with engineering behavior such as compressibility, hydraulic conductivity (permeability), compactibility, shrink-swell, and shear strength.

5.2 The liquid and plastic limits of a soil and its water content can be used to express its relative consistency or liquidity index. In addition, the plasticity index and the percentage finer than 2- μm particle size can be used to determine its activity number.

5.3 These methods are sometimes used to evaluate the weathering characteristics of clay-shale materials. When subjected to repeated wetting and drying cycles, the liquid limits of these materials tend to increase. The amount of increase is considered to be a measure of a shale’s susceptibility to weathering.

5.4 The liquid limit of a soil containing substantial amounts of organic matter decreases dramatically when the soil is oven-dried before testing. Comparison of the liquid limit of a sample before and after oven-drying can therefore be used as a qualitative measure of organic matter content of a soil (see Practice D 2487).

NOTE 1—The quality of the result produced by this standard is dependent on the competence of the personnel performing it and the suitability of the equipment and facilities used. Agencies that meet the criteria of Practice D 3740, generally, are considered capable of competent and objective testing/sampling/inspection/etc. Users of this standard are cautioned that compliance with Practice D 3740 does not in itself assure reliable results. Reliable results depend on many factors; Practice D 3740 provides a means of evaluating some of those factors.

6. Apparatus

6.1 *Liquid Limit Device*—A mechanical device consisting of a brass cup suspended from a carriage designed to control its

⁵ Annual Book of ASTM Standards, Vol 04.09.

⁶ Annual Book of ASTM Standards, Vol 14.02.

drop onto a hard rubber base. Fig. 1 shows the essential features and critical dimensions of the device. The device may be operated by either a hand crank or electric motor.

6.1.1 *Base*—A hard rubber base having a Type D Durometer hardness of 80 to 90, and resilience rebound of at least 77 % but no more than 90 %. Conduct resilience tests on the finished base with the feet attached. Details for measuring the resilience of the base are given in Annex A1.

6.1.2 *Rubber Feet*, supporting the base, designed to provide isolation of the base from the work surface, and having a Type A Durometer hardness no greater than 60 as measured on the finished feet attached to the base.

6.1.3 *Cup*, brass, with a mass, including cup hanger, of 185 to 215 g.

6.1.4 *Cam*—Designed to raise the cup smoothly and continuously to its maximum height, over a distance of at least 180° of cam rotation, without developing an upward or downward velocity of the cup when the cam follower leaves the cam. (The preferred cam motion is a uniformly accelerated lift curve.)

NOTE 2—The cam and follower design in Fig. 1 is for uniformly accelerated (parabolic) motion after contact and assures that the cup has no velocity at drop off. Other cam designs also provide this feature and may be used. However, if the cam-follower lift pattern is not known, zero velocity at drop off can be assured by carefully filing or machining the cam and follower so that the cup height remains constant over the last 20 to 45° of cam rotation.

6.1.5 *Carriage*, constructed in a way that allows convenient but secure adjustment of the height-of-drop of the cup to 10

mm (0.394 in.), and designed such that the cup and cup hanger assembly is only attached to the carriage by means of a removable pin. See Fig. 2 for definition and determination of the height-of-drop of the cup.

6.1.6 *Motor Drive (Optional)*—As an alternative to the hand crank shown in Fig. 1, the device may be equipped with a motor to turn the cam. Such a motor must turn the cam at 2 ± 0.1 revolutions per second and must be isolated from the rest of the device by rubber mounts or in some other way that prevents vibration from the motor being transmitted to the rest of the apparatus. It must be equipped with an ON-OFF switch and a means of conveniently positioning the cam for height-of-drop adjustments. The results obtained using a motor-driven device must not differ from those obtained using a manually operated device.

6.2 *Flat Grooving Tool*—A tool made of plastic or noncorroding-metal having the dimensions shown in Fig. 3. The design of the tool may vary as long as the essential dimensions are maintained. The tool may, but need not, incorporate the gage for adjusting the height-of-drop of the liquid limit device.

NOTE 3—Prior to the adoption of this test method, a curved grooving tool was specified as part of the apparatus for performing the liquid limit test. The curved tool is not considered to be as accurate as the flat tool described in 6.2 since it does not control the depth of the soil in the liquid limit cup. However, there are some data which indicate that typically the liquid limit is slightly increased when the flat tool is used instead of the curved tool.

DIMENSIONS

LETTER	A ^Δ	B ^Δ	C ^Δ	E ^Δ	F	G	H	J ^Δ	K ^Δ	L ^Δ	M ^Δ
MM	54 ± 0.5	2 ± 0.1	27 ± 0.5	56 ± 2.0	32	10	16	60 ± 1.0	50 ± 2.0	150 ± 2.0	125 ± 2.0
LETTER	N	P	R	T	U ^Δ	V	W	Z			
MM	24	28	24	45	47 ± 1.0	3.8	13	6.5			

^Δ ESSENTIAL DIMENSIONS

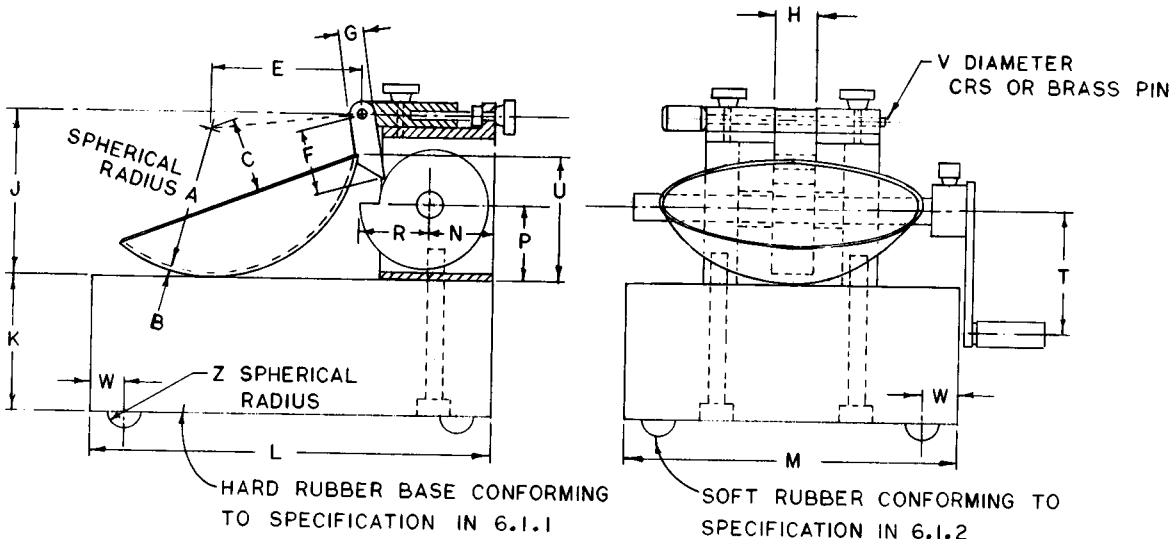

FIG. 1 Hand-Operated Liquid Limit Device

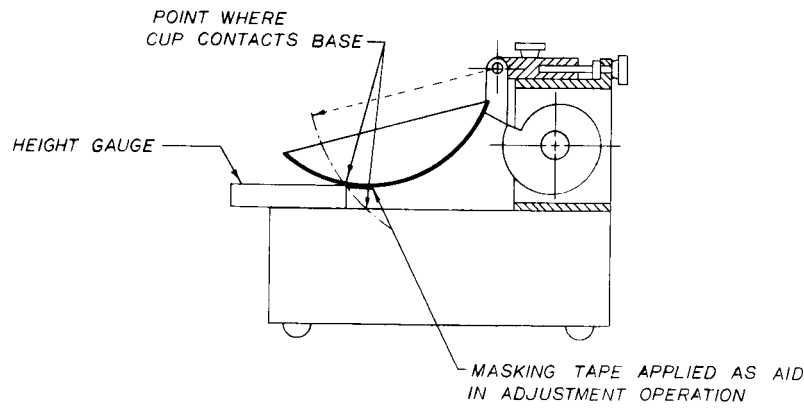

FIG. 2 Calibration for Height-of-Drop

DIMENSIONS

LETTER	A ^Δ	B ^Δ	C ^Δ	D ^Δ	E ^Δ	F ^Δ
MM	2 ± 0.1	11 ± 0.2	40 ± 0.5	8 ± 0.1	50 ± 0.5	2 ± 0.1
LETTER	G	H	J	K [□]	L ^Δ	N
MM	10 MINIMUM	13	60	10 ± 0.05	60 DEG ± 1 DEG	20

^Δ ESSENTIAL DIMENSIONS

[□] BACK AT LEAST 15 MM FROM TIP

NOTE: DIMENSION A SHOULD BE 1.9-2.0 AND DIMENSION D SHOULD BE 8.0-8.1 WHEN NEW TO ALLOW FOR ADEQUATE SERVICE LIFE

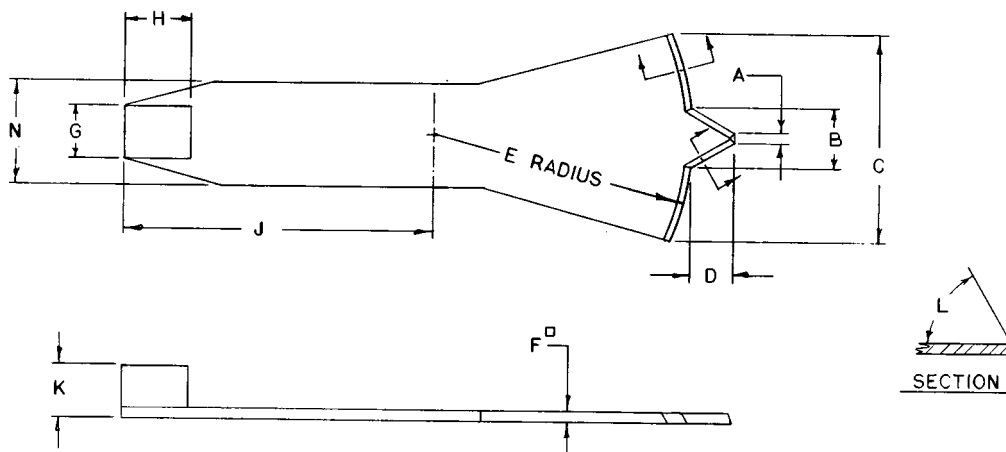

FIG. 3 Grooving Tool (Optional Height-of-Drop Gage Attached)

6.3 *Gage*—A metal gage block for adjusting the height-of-drop of the cup, having the dimensions shown in Fig. 4. The design of the tool may vary provided the gage will rest securely on the base without being susceptible to rocking, and the edge which contacts the cup during adjustment is straight, at least 10 mm (3/8 in.) wide, and without bevel or radius.

6.4 *Water Content Containers*—Small corrosion-resistant containers with snug-fitting lids for water content specimens. Aluminum or stainless steel cans 2.5 cm (1 in.) high by 5 cm (2 in.) in diameter are appropriate.

6.5 *Balance*, conforming to Specification D 4753, Class

GP1 (readability of 0.01 g).

6.6 *Mixing and Storage Container*—A container to mix the soil specimen (material) and store the prepared material. During mixing and storage, the container shall not contaminate the material in any way, and prevent moisture loss during storage. A porcelain, glass, or plastic dish about 11.4 cm (4 1/2 in.) in diameter and a plastic bag large enough to enclose the dish and be folded over is adequate.

6.7 *Plastic Limit*:

6.7.1 *Ground Glass Plate*—A ground glass plate at least 30

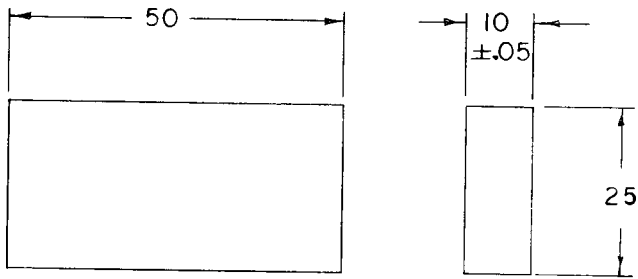

DIMENSIONS IN MILLIMETRES
FIG. 4 Height-of-Drop Gage

cm (12 in.) square by 1 cm (3/8 in.) thick for rolling plastic limit threads.

6.7.2 *Plastic Limit-Rolling Device (optional)*—A device made of acrylic conforming to the dimensions shown in Fig. 5.^{7,8} The type of unglazed paper attached to the top and bottom plate (see 16.2.2) shall be such that it does not add foreign matter (fibers, paper fragments, etc.) to the soil during the rolling process.

6.8 *Spatula*—A spatula or pill knife having a blade about 2 cm (3/4 in.) wide, and about 10 to 13 cm (3 to 4 in.) long.

6.9 *Sieve(s)*—A 200-mm (8-in.) diameter, 425- μ m (No. 40) sieve conforming to the requirements of Specification E 11 and

⁷ The plastic limit-rolling device is covered by a patent (U.S. Patent No. 5,027,660).⁷ Interested parties are invited to submit information regarding the identification of an alternative(s) to this patented item to ASTM Headquarters. Your comments will receive careful consideration at a meeting of the responsible subcommittee, which you may attend.

⁸ Bobrowski, L. J., Jr. and Griekspoor, D. M., "Determination of the Plastic Limit of a Soil by Means of a Rolling Device," *Geotechnical Testing Journal*, GTJODJ, Vol 15, No. 3, September 1992, pp. 284–287.

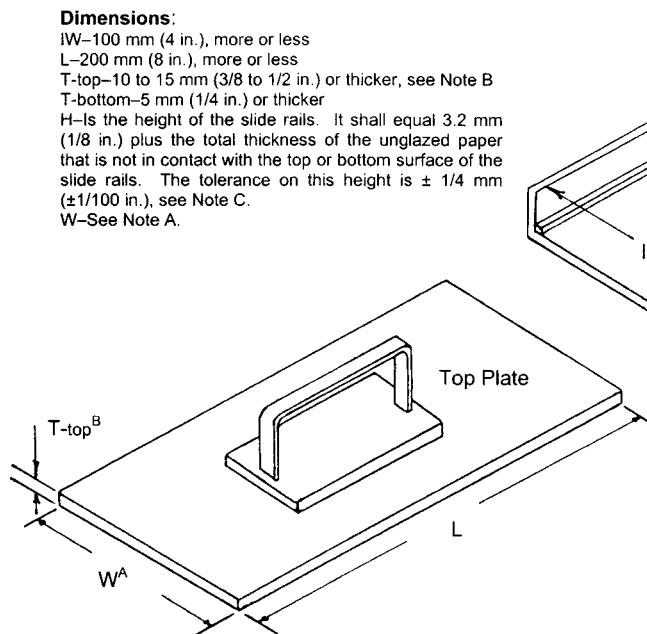

Dimensions:
 W—100 mm (4 in.), more or less
 L—200 mm (8 in.), more or less
 T-top—10 to 15 mm (3/8 to 1/2 in.) or thicker, see Note B
 T-bottom—5 mm (1/4 in.) or thicker
 H—Is the height of the slide rails. It shall equal 3.2 mm (1/8 in.) plus the total thickness of the unglazed paper that is not in contact with the top or bottom surface of the slide rails. The tolerance on this height is $\pm 1/4$ mm ($\pm 1/100$ in.), see Note C.
 W—See Note A.

having a rim at least 5 cm (2 in.) above the mesh. A 2.00-mm (No. 10) sieve meeting the same requirements may also be needed.

6.10 *Wash Bottle*, or similar container for adding controlled amounts of water to soil and washing fines from coarse particles.

6.11 *Drying Oven*, thermostatically controlled, preferably of the forced-draft type, capable of continuously maintaining a temperature of $110 \pm 5^\circ\text{C}$ ($230 \pm 9^\circ\text{F}$) throughout the drying chamber.

6.12 *Washing Pan*, round, flat-bottomed, at least 7.6 cm (3 in.) deep, and slightly larger at the bottom than a 20.3-cm (8-in.) diameter sieve.

7. Reagents and Materials

7.1 *Purity of Water*—Where distilled water is referred to in this test method, either distilled or demineralized water may be used. See Note 7 covering the use of tap water.

8. Sampling and Specimen

8.1 Samples may be taken from any location that satisfies testing needs. However, Practices C 702, D 75, and D 420 should be used as guides for selecting and preserving samples from various types of sampling operations. Samples in which specimens will be prepared using the wet-preparation method (10.1) must be kept at their as-sampled water content prior to preparation.

8.1.1 Where sampling operations have preserved the natural stratification of a sample, the various strata must be kept separated and tests performed on the particular stratum of interest with as little contamination as possible from other strata. Where a mixture of materials will be used in construction, combine the various components in such proportions that the resultant sample represents the actual construction case.

Figure 4 Notes:

- (A) The tolerance between the width of the top plate (W) and the inside width of the bottom plate (IW) shall be such that the top plate slides freely on the rails without wobbling.
- (B) The top plate shall be rigid enough so that the thickness of the rolled threads is within the tolerances given for the rail height (H).
- (C) The width of the slide rails shall be between 3 and 6 mm (1/8 and 1/4 in.).

FIG. 5 Plastic Limit-Rolling Device

8.1.2 Where data from these test methods are to be used for correlation with other laboratory or field test data, use the same material as used for those tests where possible.

8.2 *Specimen*—Obtain a representative portion from the total sample sufficient to provide 150 to 200 g of material passing the 425- μm (No. 40) sieve. Free flowing samples (materials) may be reduced by the methods of quartering or splitting. Non-free flowing or cohesive materials shall be mixed thoroughly in a pan with a spatula or scoop and a representative portion scooped from the total mass by making one or more sweeps with a scoop through the mixed mass.

9. Calibration of Apparatus

9.1 *Inspection of Wear:*

9.1.1 *Liquid Limit Device*—Determine that the liquid limit device is clean and in good working order. Check the following specific points.

9.1.1.1 *Wear of Base*—The spot on the base where the cup makes contact should be worn no greater than 10 mm ($\frac{3}{8}$ in.) in diameter. If the wear spot is greater than this, the base can be machined to remove the worn spot provided the resurfacing does not make the base thinner than specified in 6.1 and the other dimensional relationships are maintained.

9.1.1.2 *Wear of Cup*—Replace the cup when the grooving tool has worn a depression in the cup 0.1 mm (0.004 in.) deep or when the rim of the cup has been reduced to half its original thickness. Verify that the cup is firmly attached to the cup hanger.

9.1.1.3 *Wear of Cup Hanger*—Verify that the cup hanger pivot does not bind and is not worn to an extent that allows more than 3 mm ($\frac{1}{8}$ in.) side-to-side movement of the lowest point on the rim.

9.1.1.4 *Wear of Cam*—The cam shall not be worn to an extent that the cup drops before the cup hanger (cam follower) loses contact with the cam.

9.1.2 *Grooving Tools*—Inspect grooving tools for wear on a frequent and regular basis. The rapidity of wear depends on the material from which the tool is made, and the types of soils being tested. Soils containing a large proportion of fine sand particles may cause rapid wear of grooving tools; therefore, when testing these materials, tools should be inspected more frequently than for other soils.

NOTE 4—The width of the tip of grooving tools is conveniently checked using a pocket-sized measuring magnifier equipped with a millimeter scale. Magnifiers of this type are available from most laboratory supply companies. The depth of the tip of grooving tools can be checked using the depth-measuring feature of vernier calipers.

9.2 *Adjustment of Height-of-Drop*—Adjust the height-of-drop of the cup so that the point on the cup that comes in contact with the base rises to a height of 10 ± 0.2 mm. See Fig. 2 for proper location of the gage relative to the cup during adjustment.

NOTE 5—A convenient procedure for adjusting the height-of-drop is as follows: place a piece of masking tape across the outside bottom of the cup parallel with the axis of the cup hanger pivot. The edge of the tape away from the cup hanger should bisect the spot on the cup that contacts the base. For new cups, placing a piece of carbon paper on the base and allowing the cup to drop several times will mark the contact spot. Attach the cup to the device and turn the crank until the cup is raised to its

maximum height. Slide the height gage under the cup from the front, and observe whether the gage contacts the cup or the tape. (See Fig. 2.) If the tape and cup are both simultaneously contacted, the height-of-drop is ready to be checked. If not, adjust the cup until simultaneous contact is made. Check adjustment by turning the crank at 2 revolutions per second while holding the gage in position against the tape and cup. If a faint ringing or clicking sound is heard without the cup rising from the gage, the adjustment is correct. If no ringing is heard or if the cup rises from the gage, readjust the height-of-drop. If the cup rocks on the gage during this checking operation, the cam follower pivot is excessively worn and the worn parts should be replaced. Always remove tape after completion of adjustment operation.

10. Preparation of Test Specimen

10.1 *Wet Preparation Method*—Except where the dry method of specimen preparation is specified (10.2), prepare the specimen for testing as described in the following sections.

10.1.1 *Material Passes the 425- μm (No. 40) Sieve:*

10.1.1.1 Determine by visual and manual methods that the specimen from 8.2 has little or no material retained on a 425- μm (No. 40) sieve. If this is the case, prepare 150 to 200 g of material by mixing thoroughly with distilled or demineralized water on the glass plate or mixing dish using the spatula. If desired, soak the material in a mixing/storage dish with a small amount of water to soften the material before the start of mixing. If using Method A, adjust the water content of the material to bring it to a consistency that would require about 25 to 35 blows of the liquid limit device to close the groove (Note 6). For Method B, the number of blows should be between about 20 and 30 blows.

10.1.1.2 If, during mixing, a small percentage of material is encountered that would be retained on a 425- μm (No. 40) sieve, remove these particles by hand (if possible). If it is impractical to remove the coarser material by hand, remove small percentages (less than about 15 %) of coarser material by working the material (having the above consistency) through a 425- μm sieve. During this procedure, use a piece of rubber sheeting, rubber stopper, or other convenient device provided the procedure does not distort the sieve or degrade material that would be retained if the washing method described in 10.1.2 were used. If larger percentages of coarse material are encountered during mixing, or it is considered impractical to remove the coarser material by the procedures just described, wash the sample as described in 10.1.2. When the coarse particles found during mixing are concretions, shells, or other fragile particles, do not crush these particles to make them pass a 425- μm sieve, but remove by hand or by washing.

10.1.1.3 Place the prepared material in the mixing/storage dish, check its consistency (adjust if required), cover to prevent loss of moisture, and allow to stand (cure) for at least 16 h (overnight). After the standing period and immediately before starting the test, thoroughly remix the soil.

NOTE 6—The time taken to adequately mix a soil will vary greatly, depending on the plasticity and initial water content. Initial mixing times of more than 30 min may be needed for stiff, fat clays.

10.1.2 *Material Containing Particles Retained on a 425- μm (No. 40) Sieve:*

10.1.2.1 Place the specimen (see 8.2) in a pan or dish and add sufficient water to cover the material. Allow the material to soak until all lumps have softened and the fines no longer

adhere to the surfaces of the coarse particles (Note 7).

NOTE 7—In some cases, the cations of salts present in tap water will exchange with the natural cations in the soil and significantly alter the test results if tap water is used in the soaking and washing operations. Unless it is known that such cations are not present in the tap water, distilled or demineralized water should be used. As a general rule, water containing more than 100 mg/L of dissolved solids should not be used for either the soaking or washing operations.

10.1.2.2 When the material contains a large percentage of particles retained on the 425- μm (No. 40) sieve, perform the following washing operation in increments, washing no more than 0.5 kg (1 lb) of material at one time. Place the 425- μm sieve in the bottom of the clean pan. Transfer, without any loss of material, the soil-water mixture onto the sieve. If gravel or coarse sand particles are present, rinse as many of these as possible with small quantities of water from a wash bottle, and discard. Alternatively, transfer the soil-water mixture over a 2.00-mm (No. 10) sieve nested atop the 425- μm sieve, rinse the fine material through and remove the 2.00-mm sieve. After washing and removing as much of the coarser material as possible, add sufficient water to the pan to bring the level to about 13 mm ($\frac{1}{2}$ in.) above the surface of the 425- μm sieve. Agitate the slurry by stirring with the fingers while raising and lowering the sieve in the pan and swirling the suspension so that fine material is washed from the coarser particles. Disaggregate fine soil lumps that have not slaked by gently rubbing them over the sieve with the fingertips. Complete the washing operation by raising the sieve above the water surface and rinsing the material retained with a small amount of clean water. Discard material retained on the 425- μm sieve.

10.1.2.3 Reduce the water content of the material passing the 425- μm (No. 40) sieve until it approaches the liquid limit. Reduction of water content may be accomplished by one or a combination of the following methods: (a) exposing to air currents at room temperature, (b) exposing to warm air currents from a source such as an electric hair dryer, (c) decanting clear water from surface of the suspension, (d) filtering in a Büchner funnel or using filter candles, or (e) draining in a colander or plaster of Paris dish lined with high retentivity,⁹ high wet-strength filter paper. If a plaster of Paris dish is used, take care that the dish never becomes sufficiently saturated that it fails to absorb water into its surface. Thoroughly dry dish between uses. During evaporation and cooling, stir the material often enough to prevent over-drying of the fringes and soil pinnacles on the surface of the mixture. For materials containing soluble salts, use a method of water reduction (a or b) that will not eliminate the soluble salts from the test specimen.

10.1.2.4 If applicable, remove the material retained on the filter paper. Thoroughly mix this material or the above material on the glass plate or in the mixing dish using the spatula. Adjust the water content of the mixture, if necessary, by adding small increments of distilled or demineralized water or by allowing the mixture to dry at room temperature while mixing on the glass plate. If using Method A, the material should be at a water content that would require about 25 to 35 blows of the liquid limit device to close the groove. For Method B, the

number of blows should be between about 20 and 30. Put, if necessary, the mixed material in the storage dish, cover to prevent loss of moisture, and allow to stand (cure) for at least 16 h. After the standing period and immediately before starting the test, thoroughly remix the specimen.

10.2 Dry Preparation Method:

10.2.1 Dry the specimen from 8.2 at room temperature or in an oven at a temperature not exceeding 60°C until the soil clods will pulverize readily. Disaggregation is expedited if the material is not allowed to completely dry. However, the material should have a dry appearance when pulverized.

10.2.2 Pulverize the material in a mortar with a rubber-tipped pestle or in some other way that does not cause breakdown of individual particles. When the coarse particles found during pulverization are concretions, shells, or other fragile particles, do not crush these particles to make them pass a 425- μm (No. 40) sieve, but remove by hand or other suitable means, such as washing. If a washing procedure is used, follow 10.1.2.1-10.1.2.4.

10.2.3 Separate the material on a 425- μm (No. 40) sieve, shaking the sieve by hand to assure thorough separation of the finer fraction. Return the material retained on the 425- μm sieve to the pulverizing apparatus and repeat the pulverizing and sieving operations. Stop this procedure when most of the fine material has been disaggregated and material retained on the 425- μm sieve consists of individual particles.

10.2.4 Place material retained on the 425- μm (No. 40) sieve after the final pulverizing operations in a dish and soak in a small amount of water. Stir this mixture and transfer it to a 425- μm sieve, catching the water and any suspended fines in the washing pan. Pour this suspension into a dish containing the dry soil previously sieved through the 425- μm sieve. Discard material retained on the 425- μm sieve.

10.2.5 Proceed as described in 10.1.2.3 and 10.1.2.4.

MULTIPOINT LIQUID LIMIT—METHOD A

11. Procedure

11.1 Thoroughly remix the specimen (soil) in its mixing cup, and, if necessary, adjust its water content until the constancy requires about 25 to 35 blows of the liquid limit device to close the groove. Using a spatula, place a portion(s) of the prepared soil in the cup of the liquid limit device at the point where the cup rests on the base, squeeze it down, and spread it into the cup to a depth of about 10 mm at its deepest point, tapering to form an approximately horizontal surface. Take care to eliminate air bubbles from the soil pat, but form the pat with as few strokes as possible. Keep the unused soil in the mixing/storage dish. Cover the dish with a wet towel (or use other means) to retain the moisture in the soil.

11.2 Form a groove in the soil pat by drawing the tool, beveled edge forward, through the soil on a line joining the highest point to the lowest point on the rim of the cup. When cutting the groove, hold the grooving tool against the surface of the cup and draw in an arc, maintaining the tool perpendicular to the surface of the cup throughout its movement. See Fig. 6. In soils where a groove cannot be made in one stroke without tearing the soil, cut the groove with several strokes of the grooving tool. Alternatively, cut the groove to slightly less than

⁹ S and S 595 filter paper available in 320-mm circles has proven satisfactory.



FIG. 6 Grooved Soil Pat in Liquid Limit Device

required dimensions with a spatula and use the grooving tool to bring the groove to final dimensions. Exercise extreme care to prevent sliding the soil pat relative to the surface of the cup.

11.3 Verify that no crumbs of soil are present on the base or the underside of the cup. Lift and drop the cup by turning the crank at a rate of 1.9 to 2.1 drops per second until the two halves of the soil pat come in contact at the bottom of the groove along a distance of 13 mm ($\frac{1}{2}$ in.). See Fig. 7.

NOTE 8—Use of a scale is recommended to verify that the groove has closed 13 mm ($\frac{1}{2}$ in.).

11.4 Verify that an air bubble has not caused premature closing of the groove by observing that both sides of the groove have flowed together with approximately the same shape. If a bubble has caused premature closing of the groove, reform the soil in the cup, adding a small amount of soil to make up for that lost in the grooving operation and repeat 11.1-11.3. If the soil slides on the surface of the cup, repeat 11.1-11.3 at a higher water content. If, after several trials at successively higher water contents, the soil pat continues to slide in the cup or if the number of blows required to close the groove is always less



FIG. 7 Soil Pat After Groove Has Closed

than 25, record that the liquid limit could not be determined, and report the soil as nonplastic without performing the plastic limit test.

11.5 Record the number of drops, N , required to close the groove. Remove a slice of soil approximately the width of the spatula, extending from edge to edge of the soil cake at right angles to the groove and including that portion of the groove in which the soil flowed together, place in a container of known mass, and cover.

11.6 Return the soil remaining in the cup to the dish. Wash and dry the cup and grooving tool and reattach the cup to the carriage in preparation for the next trial.

11.7 Remix the entire soil specimen in the dish adding distilled water to increase the water content of the soil and decrease the number of blows required to close the groove. Repeat 11.1-11.6 for at least two additional trials producing successively lower numbers of blows to close the groove. One of the trials shall be for a closure requiring 25 to 35 blows, one for closure between 20 and 30 blows, and one trial for a closure requiring 15 to 25 blows.

11.8 Determine the water content, W^m , of the soil specimen from each trial in accordance with Test Method D 2216.

11.8.1 Determination of initial masses (container plus moist soil) should be performed immediately after completion of the test. If the test is to be interrupted for more than about 15 minutes, determine the mass of the water content specimens already obtained at the time of the interruption.

12. Calculation

12.1 Plot the relationship between the water content, W^m , and the corresponding number of drops, N , of the cup on a semilogarithmic graph with the water content as ordinates on the arithmetical scale, and the number of drops as abscissas on a logarithmic scale. Draw the best straight line through the three or more plotted points.

12.2 Take the water content corresponding to the intersection of the line with the 25-drop abscissa as the liquid limit of the soil and round to the nearest whole number. Computational methods may be substituted for the graphical method for fitting a straight line to the data and determining the liquid limit.

ONE-POINT LIQUID LIMIT—METHOD B

13. Procedure

13.1 Proceed as described in 11.1-11.5 except that the number of blows required to close the groove shall be 20 to 30. If less than 20 or more than 30 blows are required, adjust the water content of the soil and repeat the procedure.

13.2 Immediately after removing a water content specimen as described in 11.5, reform the soil in the cup, adding a small amount of soil to make up for that lost in the grooving and water content sampling orientations. Repeat 11.2-11.5, and, if the second closing of the groove requires the same number of drops or no more than two drops difference, secure another water content specimen. Otherwise, remix the entire specimen and repeat.

NOTE 9—Excessive drying or inadequate mixing will cause the number of blows to vary.

13.3 Determine water contents of specimens in accordance with 11.8.

14. Calculation

14.1 Determine the liquid limit for each water content specimen using one of the following equations:

$$LL^n = W^m \cdot \left(\frac{N}{25}\right)^{0.121}$$

or

$$LL^n = k \cdot W^m$$

where:

LL^n = one point liquid limit for given trial, %,

N = number of blows causing closure of the groove for given trial,

W^m = water content for given trial, %, and

k = factor given in Table 1.

14.1.1 The liquid limit, LL , is the average of the two trial liquid-limit values, to the nearest whole number (without the percent designation).

14.2 If the difference between the two trial liquid-limit values is greater than one percentage point, repeat the test as described in 13.1 through 14.1.1.

PLASTIC LIMIT

15. Preparation of Test Specimen

15.1 Select a 20-g or more portion of soil from the material prepared for the liquid limit test; either, after the second mixing before the test, or from the soil remaining after completion of the liquid limit test. Reduce the water content of the soil to a consistency at which it can be rolled without sticking to the hands by spreading or mixing continuously on the glass plate or in the mixing/storage dish. The drying process may be accelerated by exposing the soil to the air current from an electric fan, or by blotting with paper, that does not add any fiber to the soil. Paper such as hard surface paper toweling or high wet-strength filter paper is adequate.

16. Procedure

16.1 From this plastic-limit specimen, select a 1.5 to 2.0 g portion. Form the selected portion into an ellipsoidal mass.

16.2 Roll the soil mass by one of the following methods (hand or rolling device):

TABLE 1 Factors for Obtaining Liquid Limit from Water Content and Number of Drops Causing Closure of Groove

N (Number of Drops)	k (Factor for Liquid Limit)
20	0.973
21	0.979
22	0.985
23	0.990
24	0.995
25	1.000
26	1.005
27	1.009
28	1.014
29	1.018
30	1.022

16.2.1 *Hand Method*—Roll the mass between the palm or fingers and the ground-glass plate with just sufficient pressure to roll the mass into a thread of uniform diameter throughout its length (see Note 10). The thread shall be further deformed on each stroke so that its diameter reaches 3.2 mm ($\frac{1}{8}$ in.), taking no more than 2 min (see Note 11). The amount of hand or finger pressure required will vary greatly according to the soil being tested, that is, the required pressure typically increases with increasing plasticity. Fragile soils of low plasticity are best rolled under the outer edge of the palm or at the base of the thumb.

NOTE 10—A normal rate of rolling for most soils should be 80 to 90 strokes per minute, counting a stroke as one complete motion of the hand forward and back to the starting position. This rate of rolling may have to be decreased for very fragile soils.

NOTE 11—A 3.2-mm ($\frac{1}{8}$ -in.) diameter rod or tube is useful for frequent comparison with the soil thread to ascertain when the thread has reached the proper diameter.

16.2.2 *Rolling Device Method*—Attach smooth unglazed paper to both the top and bottom plates of the plastic limit-rolling device. Place the soil mass on the bottom plate at the midpoint between the slide rails. Place the top plate in contact with the soil mass(es). Simultaneously apply a slight downward force and back and forth motion to the top plate so that the top plate comes into contact with the side rails within 2 min (see Notes 10 and 12). During this rolling process, the end(s) the soil thread(s) shall not contact the side rail(s). If this occurs, roll a smaller mass of soil (even if it is less than that mentioned in Section 16.1).

NOTE 12—In most cases, two soil masses (threads) can be rolled simultaneously in the plastic limit-rolling device.

16.3 When the diameter of the thread becomes 3.2 mm, break the thread into several pieces. Squeeze the pieces

together, knead between the thumb and first finger of each hand, reform into an ellipsoidal mass, and re-roll. Continue this alternate rolling to a thread 3.2 mm in diameter, gathering together, kneading and re-rolling, until the thread crumbles under the pressure required for rolling and the soil can no longer be rolled into a 3.2-mm diameter thread (see Fig. 8). It has no significance if the thread breaks into threads of shorter length. Roll each of these shorter threads to 3.2 mm in diameter. The only requirement for continuing the test is that these threads can be reformed into an ellipsoidal mass and rolled out again. The operator shall at no time attempt to produce failure at exactly 3.2-mm diameter by allowing the thread to reach 3.2 mm, then reducing the rate of rolling or the hand pressure, or both, while continuing the rolling without further deformation until the thread falls apart. It is permissible, however, to reduce the total amount of deformation for feebly plastic soils by making the initial diameter of the ellipsoidal mass nearer to the required 3.2-mm final diameter. If crumbling occurs when the thread has a diameter greater than 3.2 mm, this shall be considered a satisfactory end point, provided the soil has been previously rolled into a thread 3.2 mm in diameter. Crumbling of the thread will manifest itself differently with the various types of soil. Some soils fall apart in numerous small aggregations of particles, others may form an outside tubular layer that starts splitting at both ends. The splitting progresses toward the middle, and finally, the thread falls apart in many small platy particles. Fat clay soils require much pressure to deform the thread, particularly as they approach the plastic limit. With these soils, the thread breaks into a series of barrel-shaped segments about 3.2 to 9.5 mm ($\frac{1}{8}$ to $\frac{3}{8}$ in.) in length.

16.4 Gather the portions of the crumbled thread together

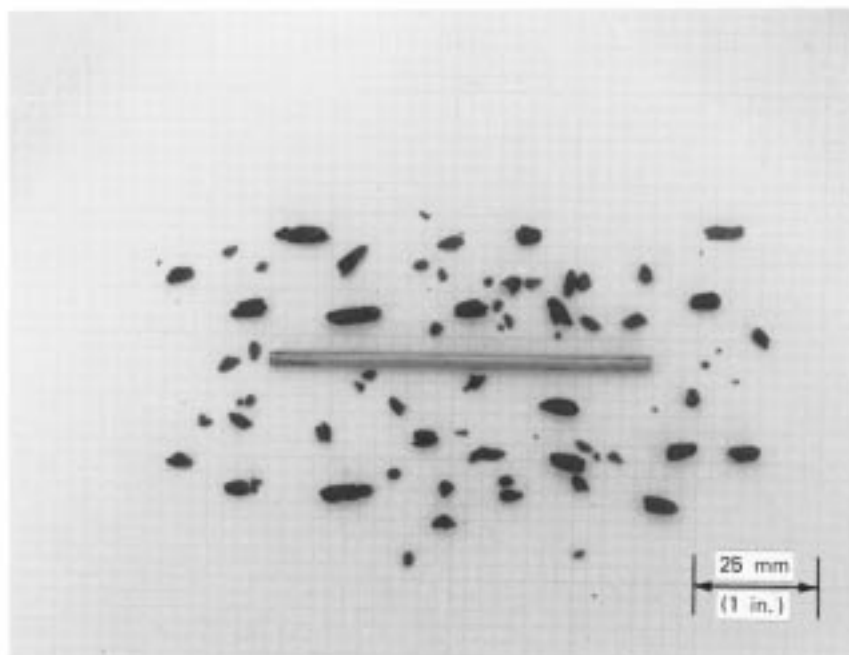

FIG. 8 Lean Clay Soil at the Plastic Limit

and place in a container of known mass. Immediately cover the container.

16.5 Select another 1.5 to 2.0-g portion of soil from the plastic-limit specimen and repeat the operations described in 16.1 and 16.2 until the container has at least 6 g of soil.

16.6 Repeat 16.1-16.5 to make another container holding at least 6 g of soil. Determine the water content of the soil contained in the containers in accordance with Test Method D 2216. See 11.8.1.

17. Calculation

17.1 Compute the average of the two water contents (trial plastic limits) and round to the nearest whole number. This value is the plastic limit, *PL*. Repeat the test if the difference between the two trial plastic limits is greater than the acceptable range for two results listed in Table 2 for single-operator precision, that is, 1.4 percentage points; i.e., (2.8 × 0.5).

PLASTICITY INDEX

18. Calculation

18.1 Calculate the plasticity index as follows:

$$PI = LL - PL$$

where:

LL = liquid limit (whole number), and

PL = plastic limit (whole number).

18.1.1 Both *LL* and *PL* are whole numbers. If either the liquid limit or plastic limit could not be determined, or if the plastic limit is equal to or greater than the liquid limit, report the soil as nonplastic, NP.

19. Report

19.1 Report the following information:

19.1.1 Sample identifying information,

19.1.2 Any special specimen selection process used, such as removal of sand lenses from undisturbed sample,

19.1.3 Report sample as air-dried if the sample was air-dried before or during preparation,

19.1.4 Liquid limit, plastic limit, and plasticity index to the nearest whole number, omitting the percent designation. If the

liquid limit or plastic limit tests could not be performed, or if the plastic limit is equal to or greater than the liquid limit, report the soil as nonplastic, NP,

19.1.5 Estimate of the percentage of sample retained on the 425-µm (No. 40) sieve, and

19.1.6 Procedure by which liquid limit was performed, if it differs from the multipoint method.

20. Precision and Bias

20.1 *Precision*—Criteria for judging the acceptability of test results obtained by these test methods on a range of soil types are given in Tables 2 and 3. In performing these test methods, Method A and the Wet Preparation Method (except soil was air-dried) were used.

20.1.1 These estimates of precision are based on the results of the interlaboratory program conducted by the ASTM Reference Soils and Testing Program.¹⁰ In this program, some laboratories performed three replicate tests per soil type (triplicate test laboratory), while other laboratories performed a single test per soil type (single-test laboratory). A description of the soils tested is given in 20.1.5. The precision estimates vary with soil type and method(s) used. Judgment is required when applying these estimates to another soil and method used (Method A or B, or Wet or Dry Preparation Method).

20.1.2 The data in Table 2 are based on three replicate tests performed by each triplicate test laboratory on each soil type. The single operator and multilaboratory standard deviation shown in Table 2, Column 4, were obtained in accordance with Practice E 691, which recommends each testing laboratory perform a minimum of three replicate tests. Results of two properly conducted tests performed by the same operator on the same material, using the same equipment, and in the shortest practical period of time should not differ by more than the single-operator d2s limits shown in Table 2, Column 5. For definition of d2s see Footnote C in Table 2. Results of two properly conducted tests performed by different operators and

¹⁰ Supporting data are available from ASTM Headquarters. Request RR: D18-1013.

TABLE 2 Summary of Test Results from Triplicate Test Laboratories (Atterberg Limits)

(1) Soil Type	(2) Number of Triplicate Test Laboratories			(3) Average Value ^A (Percentage Points)			(4) Standard Deviation ^B (Percentage Points)			(5) Acceptable Range of Two Results ^C (Percentage Points)		
	LL	PL	PI	LL	PL	PI	LL	PL	PI	LL	PL	PI
	<i>Single-Operator Results (Within-Laboratory Repeatability)</i>											
CH	13	13	13	59.8	20.6	39.2	0.7	0.5	0.8	2	1	2
CL	14	13	13	33.4	19.9	13.6	0.3	0.4	0.5	1	1	1
ML	12	11	11	27.4	23.4 ^D	4.1 ^D	0.5	0.3	0.6	2	1	2
	<i>Multilaboratory Results (Between-Laboratory Reproducibility)</i>											
CH	13	13	13	59.8	20.6	39.2	1.3	2.0	2.5	4	6	7
CL	14	13	13	33.4	19.9	13.6	1.0	1.2	1.7	3	3	5
ML	12	11	11	27.4	23.4 ^D	4.1 ^D	1.3	0.9	1.9	4	3	5

^AThe number of significant digits and decimal places presented are representative of the input data. In accordance with Practice D 6026, the standard deviation and acceptable range of results can not have more decimal places than the input data.

^BStandard deviation is calculated in accordance with Practice E 691 and is referred to as the 1s limit.

^CAcceptable range of two results is referred to as the d2s limit. It is calculated as $1.960 \cdot \sqrt{2} \cdot 1s$, as defined by Practice E 177. The difference between two properly conducted tests should not exceed this limit. The number of significant digits/decimal places presented is equal to that prescribed by this test method or Practice D 6026. In addition, the value presented can have the same number of decimal places as the standard deviation, even if that result has more significant digits than the standard deviation.

^DFor the ML soil, 2 out of 14 triplicate test laboratories reported the soil as nonplastic.

TABLE 3 Summary of Single-Test Result from Each Laboratory (Atterberg Limits)^A

(1) Soil Type	(2) Number of Test Laboratories	(3) Average Value (Percentage Points)			(4) Standard Deviation (Percentage Points)			(5) Acceptable Range of Two Results (Percentage Points)		
		Type Test								
		LL	PL	PI	LL	PL	PI	LL	PL	PI
CH	24	59.9	20.4	39.5	2.1	2.7	3.1	6	7	9
CL	24	33.3	19.9	13.4	0.8	1.3	1.6	2	4	4
ML	18	27.1	23.2 ^B	3.9 ^B	1.3	1.2	1.8	4	3	5

^AFor column footnotes, see Table 3.

^BFor the ML soil, 6 out of 24 laboratories reported the soil as nonplastic.

on different days should not differ by more than the multilaboratory d_{2s} limits shown in Table 2, Column 5.

20.1.3 In the ASTM Reference Soils and Testing Program, many of the laboratories performed only a single test on each soil type. This is common practice in the design and construction industry. The data for each soil type in Table 3 are based upon the first test results from the triplicate test laboratories and the single test results from the other laboratories. Results of two properly conducted tests performed by two different

laboratories with different operators using different equipment and on different days should not vary by more than the d_{2s} limits shown in Table 3, Column 5. The results in Table 2 and Table 3 are dissimilar because the data sets are different.

20.1.4 Table 2 presents a rigorous interpretation of triplicate test data in accordance with Practice E 691 from pre-qualified laboratories. Table 3 is derived from test data that represents common practice.

20.1.5 *Soil Types*—Based on the multilaboratory test results, the soils used in the program are described below in accordance with Practice D 2487. In addition, the local names of the soils are given.

CH—Fat clay, CH, 99 % fines, LL=60, PI=39, grayish brown, soil had been air dried and pulverized. Local name—Vicksburg Buckshot Clay

CL—Lean clay, CL, 89 % fines, LL=33, PI=13, gray, soil had been air dried and pulverized. Local name—Annapolis Clay

ML—Silt, ML, 99 % fines, LL=27, PI=4, light brown, soil had been air dried and pulverized. Local name—Vicksburg Silt

20.2 *Bias*—There is no acceptable reference value for these test methods; therefore, bias cannot be determined.

21. Keywords

21.1 activity; Atterberg limits; liquid limit; plasticity index; plastic limit

ANNEX

(Mandatory Information)

A1. Resilience Tester

A1.1 A device for measuring the resilience of liquid limit device bases is shown in Fig. A1.1. The device consists of a clear acrylic plastic tube and cap, a $\frac{5}{16}$ -in. diameter steel ball, and a small bar magnet. The cylinder may be cemented to the cap or threaded as shown. The small bar magnet is held in the recess of the cap and the steel ball is fixed into the recess in the underside of the cap with the bar magnet. The cylinder is then turned upright and placed on the top surface of the base to be

tested. Holding the tube lightly against the liquid limit device base with one hand, release the ball by pulling the magnet out of the cap. Use the scale markings on the outside of the cylinder to determine the highest point reached by the bottom of the ball. Repeat the drop at least three times, placing the tester in a different location for each drop. Tests should be conducted at room temperature.

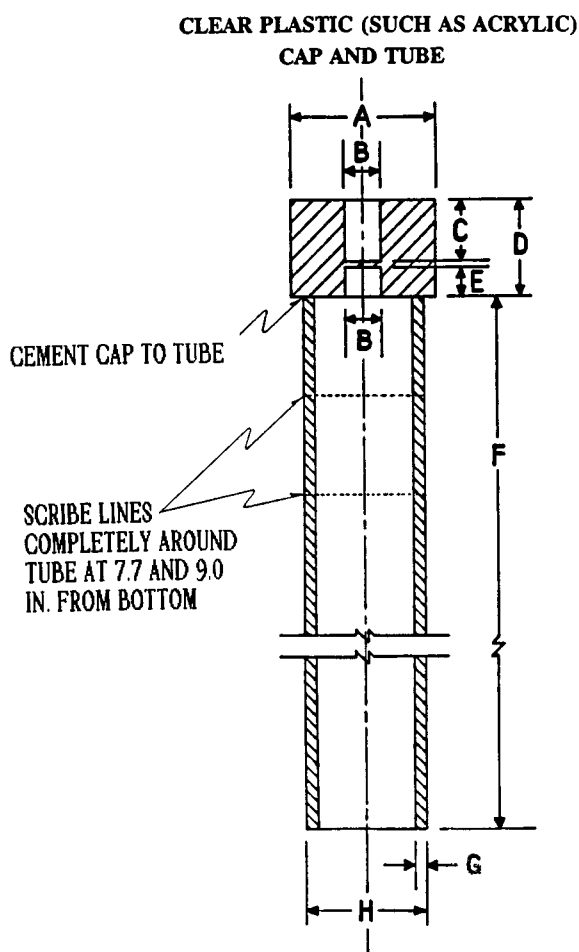

TABLE OF MEASUREMENTS

DIMENSION	DESCRIPTION	ENGLISH, in.	METRIC, mm
A	DIAM. OF CAP	1 1/2	38.10
B	DIAM. OF HOLE	3/8	9.52
C	DEPTH OF HOLE	10/16	15.88
D	HEIGHT OF CAP	1	25.40
E	DEPTH OF HOLE	5/16	7.94
F	LENGTH OF TUBE	10	254.00
G	WALL THICKNESS	1/8	3.18
H	O.D. OF TUBE	1 1/4	31.75

FIG. A1.1 Resilience Tester

SUMMARY OF CHANGES

Committee D18 has identified the location of selected changes to this standard since the last issue (1998) that may impact the use of this standard.

- (1) Replaced “procedure” with “method,” when the topic covers how one is to perform a task.
- (2) In Scope covering “units,” clarified that the standard units for resilience tester are in inch-pound, not metric.
- (3) Where applicable, replaced “weight” with “mass” or reworded to remove such terms as “weight,” “weighing,” or “weigh.”
- (4) Where applicable, replaced “natural” as an adjective to water content with such terms as “its” or “as-sampled.”
- (5) In Apparatus, under 6.6, “storage container” was changed to “mixing and storage container” and subsection reworded to indicate this container/dish may be used to mix the soil. Remaining sections in the standard, where applicable, were reworded to indicate “storage dish” may also be the “mixing dish.”
- (6) In Section 8, changed title to include “Specimen,” and where applicable reworded to distinguish between the sample and the specimen before processing using the wet or dry preparation method.

- (7) Under Preparation of Test Specimen: The subsections covering the wet and dry preparation methods were reworded to include the required number of blows for Method A and B. In addition, used the term “material” instead of soil or sample, whenever applicable, and replaced “grains” with “particle.”.
- (8) Under One-Point Liquid Limit, Method B, Section 13 on Preparation of Test Specimen was removed since the information given in that section was moved to 10.1.2.4.
- (9) In the calculation sections, defined that the calculated test result is rounded to the nearest whole number.
- (10) References to Practice C 670 were deleted in text, and references to Practices D 3740, D 6026, E 177, and E 691 were incorporated.
- (11) At the end of the Significance and Use section, a new Note 1 was added referencing Practice D 3740 in accordance with D18 policy, and all subsequent notes were renumbered.
- (12) Section 20.1 on Precision was revised completely.
- (13) In Table 1, corrected the factor for 20 number of drops.
- (14) Appendix X1 was changed to Annex A1, and the scribe

line at “8.0” in Fig. A1.1 was changed to “7.7.”

The American Society for Testing and Materials takes no position respecting the validity of any patent rights asserted in connection with any item mentioned in this standard. Users of this standard are expressly advised that determination of the validity of any such patent rights, and the risk of infringement of such rights, are entirely their own responsibility.

This standard is subject to revision at any time by the responsible technical committee and must be reviewed every five years and if not revised, either reapproved or withdrawn. Your comments are invited either for revision of this standard or for additional standards and should be addressed to ASTM Headquarters. Your comments will receive careful consideration at a meeting of the responsible technical committee, which you may attend. If you feel that your comments have not received a fair hearing you should make your views known to the ASTM Committee on Standards, at the address shown below.

This standard is copyrighted by ASTM, 100 Barr Harbor Drive, PO Box C700, West Conshohocken, PA 19428-2959, United States. Individual reprints (single or multiple copies) of this standard may be obtained by contacting ASTM at the above address or at 610-832-9585 (phone), 610-832-9555 (fax), or service@astm.org (e-mail); or through the ASTM website (www.astm.org).