



Standard Test Method for Compressive Strength of Hydraulic-Cement Mortars (Using Portions of Prisms Broken in Flexure)¹

This standard is issued under the fixed designation C 349; the number immediately following the designation indicates the year of original adoption or, in the case of revision, the year of last revision. A number in parentheses indicates the year of last reapproval. A superscript epsilon (ϵ) indicates an editorial change since the last revision or reapproval.

1. Scope

1.1 This test method covers the determination of the compressive strength of hydraulic-cement mortars, using for the test specimens portions of prisms made and broken in flexure in accordance with Test Method C 348.

1.2 The values stated in SI units are to be regarded as the standard. The values in parentheses are for information only.

1.3 Values in SI units shall be obtained by measurement in SI units or by appropriate conversion, using the Rules for Conversion and rounding given in Standard IEEE/ASTM SI 10, of measurements made in other units.

1.4 *This standard does not purport to address all of the safety concerns, if any, associated with its use. It is the responsibility of the user of this standard to establish appropriate safety and health practices and determine the applicability of regulatory limitations prior to use. (Warning—Fresh hydraulic cementitious mixtures are caustic and may cause chemical burns to skin and tissue upon prolonged exposure.)²*

2. Referenced Documents

2.1 ASTM Standards:

C 109/C 109M Test Method for Compressive Strength of Hydraulic Cement Mortars (Using 2-in. or 50-mm Cube Specimens)³

C 348 Test Method for Flexural Strength of Hydraulic Cement Mortars³

C 670 Practice for Preparing Precision and Bias Statements for Test Methods for Construction Materials⁴

IEEE/ASTM SI 10 Standard for Use of the International System of Units (SI): The Modern Metric System⁵

3. Significance and Use

3.1 This method provides a means of obtaining compressive strength values from the same specimens previously used for

flexural strength determinations by Test Method C 348. The compressive strength values are for reference purposes, and not as substitutes for values (using 50-mm (2-in.) cubes) obtained by Test Method C 109/C 109M for cement acceptance.³

4. Apparatus

4.1 *Bearing Plates*—The bearing plates shall be not less than 25 mm in thickness and shall be made of a hard metal. The surfaces of the bearing plates that are placed in contact with the specimens shall be 40.0 ± 0.1 -mm by 50.8-mm rectangles, with the 50.8-mm dimension at right angles to the longitudinal axis of the prism. The bearing plate surfaces in contact with the specimen shall have a Rockwell hardness of not less than 60 HRC. These surfaces shall not depart from plane surfaces by more than 0.01 mm when the plates are new and shall be maintained within a permissible variation of 0.03 mm.

4.2 *Device for Aligning Bearing Plates*—A device for aligning the bearing plates to ensure the proper location of the upper plate with reference to the lower plate is shown in Fig. 1. If the upper bearing plate does not have free movement within the aligning plates, these shall be separated from the bottom plate by insertion of 0.05-mm shims on each side of the bottom bearing plate, and the two 6-mm pins in the upper bearing plate filed down just sufficiently to permit free up and down movement in the slots at the top of the aligning plates.

4.3 *Testing Machine*—The testing machine shall conform to the requirements prescribed in Test Method C 109/C 109M, except that the testing machine shall be of the hydraulic type.

5. Test Specimens

5.1 Both portions from each prism broken in flexure shall be used for compression testing, except that the broken portions of prisms selected for the compression test shall have a length of not less than 65 mm and shall be free of cracks, chipped surfaces, or other obvious defects.

6. Procedure

6.1 *Determination of Compressive Strength*—During the interval between flexure tests of the prisms and testing the broken portions as modified cubes, cover the specimens for the 24-h test with waterproof plastic and completely immerse all other specimens in water at a temperature of $23 \pm 2.0^\circ\text{C}$ ($73 \pm$

¹ This test method is under the jurisdiction of ASTM Committee C01 on Cement and is the direct responsibility of Subcommittee C01.27 on Strength.

Current edition approved June 10, 2002. Published August 2002. Originally published as C 349 – 54 T. Last previous edition C 349 – 97.

² See the section on Safety, Manual of Cement Testing, *Annual Book of ASTM Standards*, Vol 04.01.

³ *Annual Book of ASTM Standards*, Vol 04.01.

⁴ *Annual Book of ASTM Standards*, Vol 04.02.

⁵ *Annual Book of ASTM Standards*, Vol 14.04.

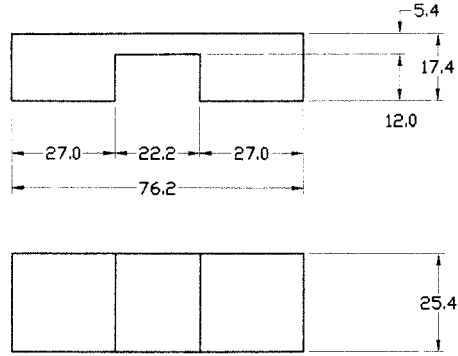
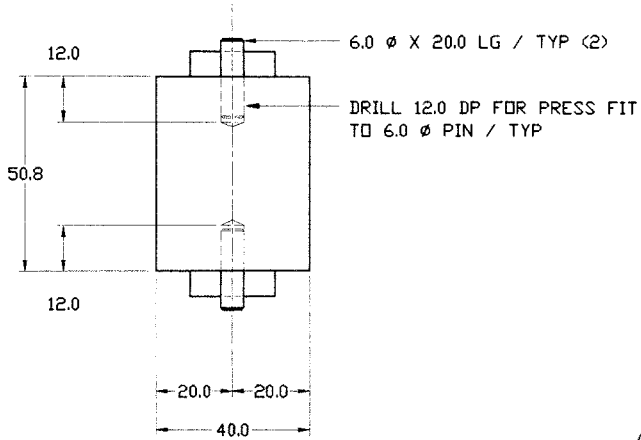

DETAIL / SPECIMEN CENTERING GUIDE
Scale: None

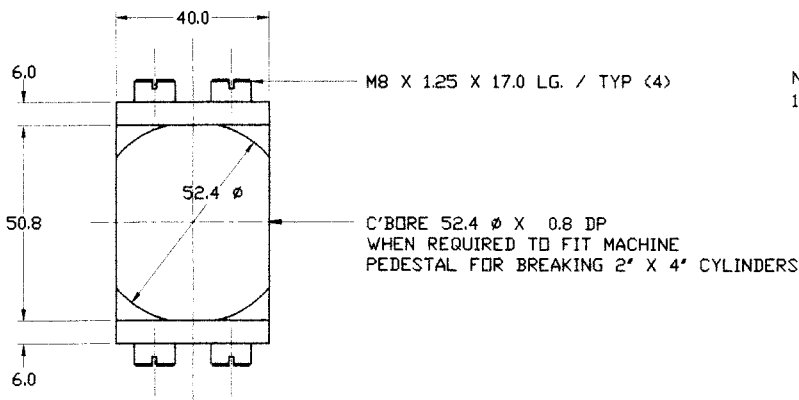
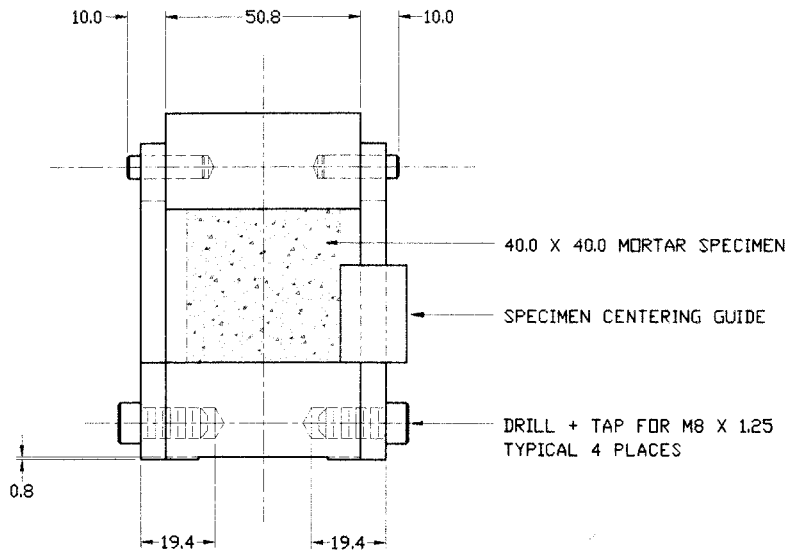
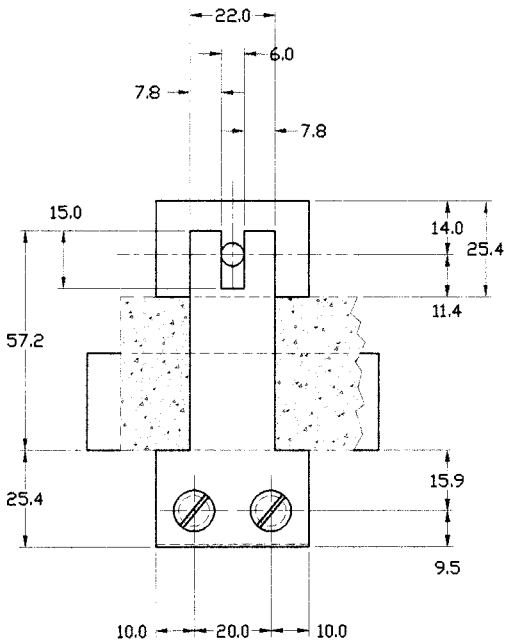

NOTES:
1. ALL DIMENSIONS EXPRESSED IN MILLIMETERS

DETAIL / BEARING PLATES
Scale: None

SI Equivalents

in.	1/32	1/4	5/16	3/8	0.462	1/2	9/16	5/8	3/4	7/8	1	1 1/16	1 1/4	2	2 1/16	2 1/2	3
mm	0.8	6.4	7.9	9.5	11.7	13	14.3	16	19	22.2	25	27	44.5	51	52.4	64	76

FIG. 1 Bearing Plates and Bearing Plate Aligning Device for Testing 40 by 40 by 160-mm Mortar Prisms as Modified Cubes

3°F) until the time of testing. Wipe the specimen to a surface-dry condition, and remove any sand grains or incrustations from the faces that will be in contact with the bearing plates of the testing apparatus. Check these faces by application of a straightedge. If there is appreciable curvature, grind the face or faces to plane surfaces or discard the specimen (Note 1). Center the pedestal usually provided for breaking 50 by 100-mm (2 by 4-in.) cylinders on the base bearing block of the machine, and center the bearing plate assembly on top of this pedestal. If the testing machine has no provisions for automatic accurate centering of a pedestal exactly below the center of its upper spherical bearing head, a hardened steel cylinder of suitable diameter and height and with parallel plane end faces may be used, provided that the bearing plate assembly is centered accurately below the center of the upper bearing head after the specimen has been placed in proper position in the bearing plate assembly. Apply the specimen aligning guide to the outside of one of the aligning plates of the bearing plate assembly, with the lugs at each end resting on or slightly above the edge of the bearing face of the bottom plate. Turn the specimen on its side with respect to its position as molded and place it in the device with the bottom as molded in contact with the aligning lugs, holding the aligning guide against the aligning plate firmly with one hand. Then remove the aligning guide without disturbing the position of the specimen and apply the load in accordance with the Procedure section of Test Method C 109/C 109M. The testing of the broken portions as modified cubes shall follow breaking in flexure within 10 min for 24-h specimens and within 30 min for all other specimens.

NOTE 1—Modified Cube Faces—Results much lower than the true strength will be obtained by loading faces of the modified cube that are not truly plane surfaces. It is essential, therefore, that molds be kept scrupulously clean, as otherwise large irregularities in the surfaces will occur. Instruments for cleaning molds should always be softer than the metal in the molds to prevent wear. In case grinding of modified cube faces is necessary, it can be accomplished best by rubbing the specimen on a sheet of fine emery paper or cloth glued to a plane surface, using only moderate pressure. Since such grinding is tedious for more than a few thousandths of an inch or hundredth of a millimetre, it is recommended that where more than this is found necessary, the specimen be discarded.

7. Calculation

7.1 Record the total maximum load indicated by the testing machine and calculate the compressive strength in megapascals to the nearest 0.1 MPa, as follows:

$$S_c = 0.00062 P \quad (1)$$

where:

S_c = compressive strength, MPa, and

P = total maximum load, N.

8. Faulty Specimens and Retests

8.1 Specimens that are manifestly faulty or that result in strengths differing by more than 10 % from the average value of all test specimens made from the same sample and tested at the same period shall not be considered in determining the compressive strength. After discarding strength values, if less than two strength values are left for determining the compressive strength at any given period a retest shall be made.

NOTE 2—Reliable strength results depend upon careful observance of all of the specified requirements and procedures. Erratic results at a given test period indicate that some of the requirements and procedures have not been carefully observed; for example, those covering the testing of the modified cubes, as prescribed in Sections 5 and 6. Specimens exhibiting oblique fractures on breaking, due to improper centering in the compression machine or to lateral movement of one of the testing machine heads during loading, will often indicate lower strengths than specimens showing a normal pyramidal fracture.

9. Precision and Bias

9.1 *Precision*—The following precision statements are applicable when a test result is the average of compressive strength tests of six modified cubes (using portions of prisms broken in flexure) molded from a single batch of mortar and tested at the same age. They are applicable to mortars made with Type I, IA, IS, or III cement tested at 3, 7, or 28 days (1, 3, or 7 days for Type III cement).

9.1.1 *Multilaboratory Precision*—The multilaboratory coefficient of variation has been found to be 6.3 %. Therefore, results of properly conducted tests of single batches by two different laboratories should not differ by more than 17.8 % of their average (Note 3).

NOTE 3—These numbers represent, respectively, the (1s%) and (d2s%) limits as described in Practice C 670.

9.1.2 *Single-Laboratory Precision*—The single-laboratory coefficient of variation has been found to be 3.5 %. Therefore, results of two properly conducted tests of single batches of mortar made with the same materials either on the same day or within the same week should not differ from each other by more than 9.9 % of their average (Note 3).

9.2 *Bias*—The procedure in this test method has no bias because the value of compressive strength is defined in terms of the test method.

10. Keywords

10.1 compressive strength; hydraulic-cement mortar; hydraulic-cement strength; mortar strength; strength

For additional useful information on details of cement test methods, reference may be made to the “Manual of Cement Testing,” which appears in the *Annual Book of ASTM Standards* Vol 04.01.

ASTM International takes no position respecting the validity of any patent rights asserted in connection with any item mentioned in this standard. Users of this standard are expressly advised that determination of the validity of any such patent rights, and the risk of infringement of such rights, are entirely their own responsibility.

This standard is subject to revision at any time by the responsible technical committee and must be reviewed every five years and if not revised, either reapproved or withdrawn. Your comments are invited either for revision of this standard or for additional standards and should be addressed to ASTM International Headquarters. Your comments will receive careful consideration at a meeting of the responsible technical committee, which you may attend. If you feel that your comments have not received a fair hearing you should make your views known to the ASTM Committee on Standards, at the address shown below.

This standard is copyrighted by ASTM International, 100 Barr Harbor Drive, PO Box C700, West Conshohocken, PA 19428-2959, United States. Individual reprints (single or multiple copies) of this standard may be obtained by contacting ASTM at the above address or at 610-832-9585 (phone), 610-832-9555 (fax), or service@astm.org (e-mail); or through the ASTM website (www.astm.org).